

Load Rating Chart

Model 4077S



© Manitex

NOTE: Additional copies of this Load Rating Chart can be purchased from your Manitex Distributor. When ordering, use the part number shown in the bottom left corner of this page.

RANGE DIAGRAM - FULLY EXTENDED OUTRIGGER CONFIGURATION -

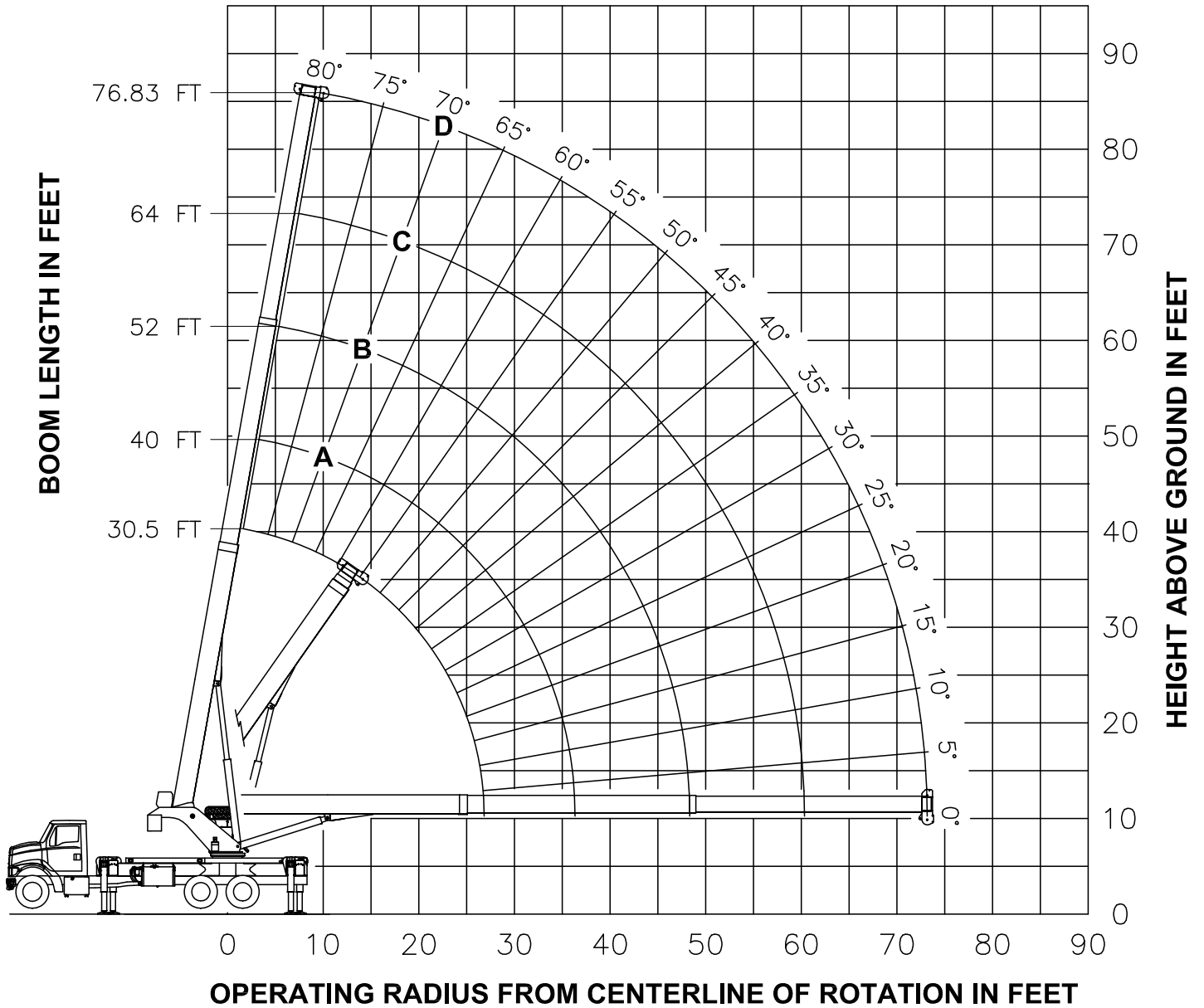

**USE THIS CHART ONLY
WHEN ALL OUTRIGGERS
ARE FULLY EXTENDED**

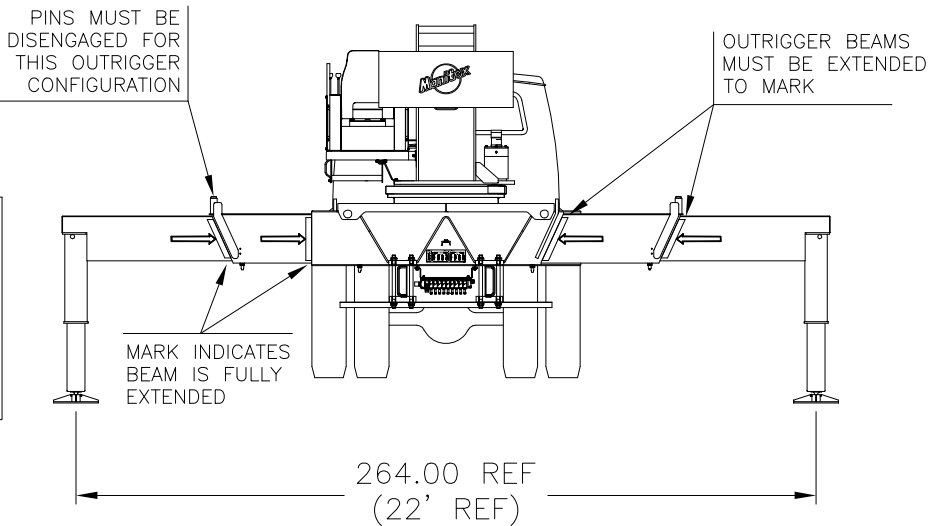

- FULLY EXTENDED OUTRIGGER CONFIGURATION -

MAIN BOOM LOAD RATINGS IN LBS WITH OUTRIGGERS PLACED AS SHOWN AND THE CRANE LEVEL										
LMI CODE #1										
OPERATING RADIUS	LOADED BOOM ANGLE		BOOM LENGTH AND MARKER							
	°	FT	°	FT	A	B	C	D		
	°	30.5 FT	°	40 FT	°	52 FT	°	64 FT	°	76.83 FT
5	75	80000								
8	69	61760	74	55500	79	47500				
10	65	53930	71	50920	76	47500	80	38000		
12	61	48090	68	45240	74	42760	78	35050	80	28410
15	54	41110	64	38890	71	36570	75	30890	78	25500
20	41	31330	55	31330	65	29590	70	25850	74	21670
25	21	22670	46	23080	58	23320	65	21930	70	18870
30			34	17220	51	17460	60	17580	66	16470
35			16	13420	44	13690	55	13810	62	13890
40					34	10950	49	11100	58	11190
45					22	8790	42	8960	53	9050
50							35	7360	48	7450
55							25	6110	43	6210
60							7	5090	36	5230
65									29	4420
70									19	3740

RANGE DIAGRAM - INTERMEDIATE SPREAD CONFIGURATION - (MID EXTEND)

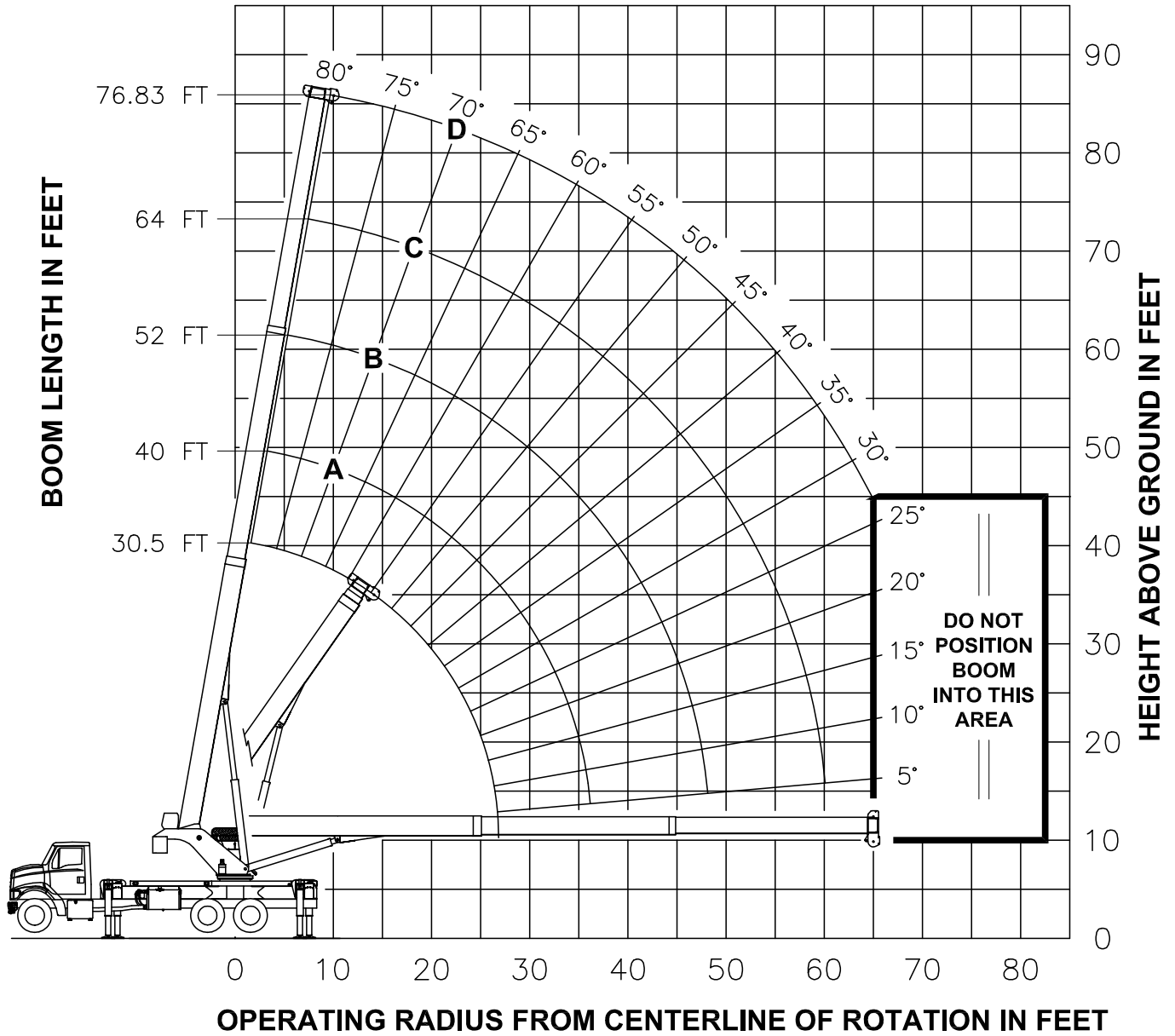

NOTE : LIFTING PERSONNEL WITH CRANE IN THIS OUTRIGGER CONFIGURATION IS STRICTLY PROHIBITED. USE ONLY FULLY EXTENDED OUTRIGGER CONFIGURATION WHEN LIFTING PERSONNEL.

USE THIS CHART ONLY WHEN ALL OUTRIGGERS ARE IN THE INTERMEDIATE POSITION

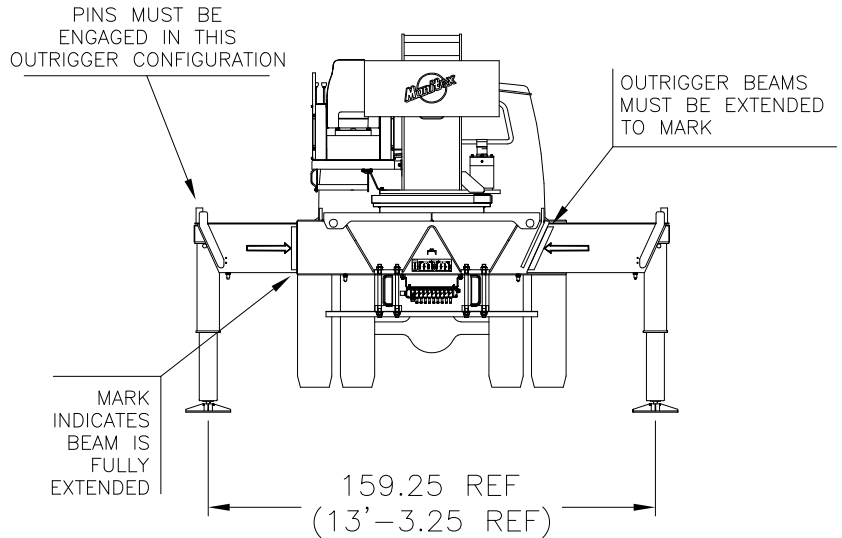

- INTERMEDIATE OUTRIGGER CONFIGURATION -

MAIN BOOM LOAD RATINGS IN LBS WITH OUTRIGGERS PLACED AS SHOWN AND THE CRANE LEVEL										
LMI CODE #9										
OPERATING HEIGHT	LOADED BOOM ANGLE		BOOM LENGTH AND MARKER							
			A		B		C		D	
	°	30.5 FT	°	40 FT	°	52 FT	°	64 FT	°	76.83 FT
5	75	80000								
8	69	61760	74	55500	79	47500				
10	65	53930	71	50920	76	47500	80	38000		
12	61	43350	68	43890	74	42760	78	35050	80	28410
15	54	26390	64	26820	71	27110	75	27300	78	25500
20	41	15010	55	15380	65	15620	70	15760	74	15860
25	21	9770	46	10160	58	10380	65	10510	70	10590
30			34	7150	51	7380	60	7500	66	7570
35			16	5170	44	5430	55	5550	62	5620
40					34	4050	49	4180	58	4240
45					22	3020	42	3160	53	3230
50							35	2370	48	2450
55							25	1740	43	1820
60							7	1200	36	1310
65									29	890

RANGE DIAGRAM - FULLY RETRACTED OUTRIGGER CONFIGURATION -

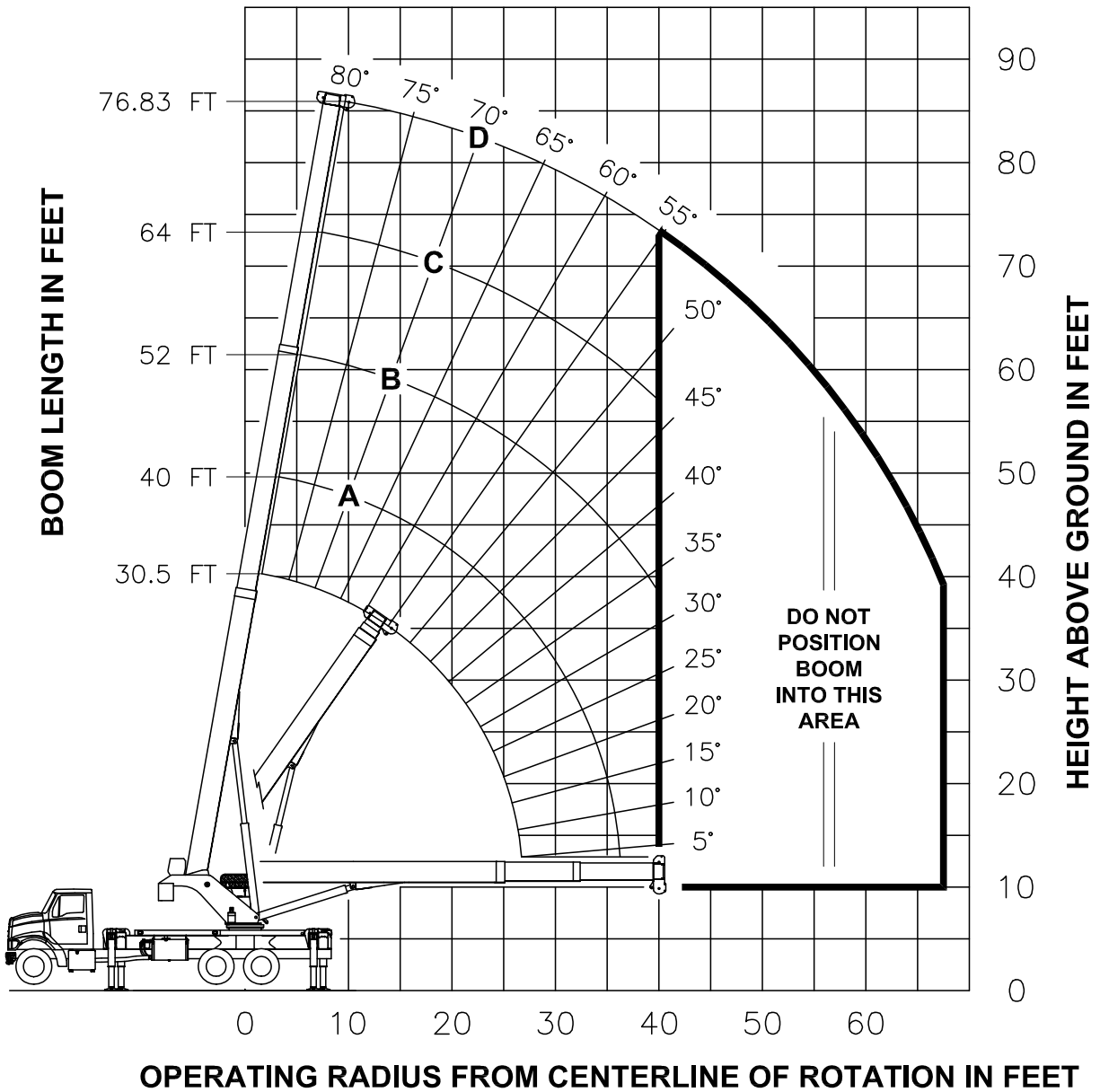

NOTE : LIFTING PERSONNEL WITH CRANE IN THIS OUTRIGGER CONFIGURATION IS STRICTLY PROHIBITED. USE ONLY FULLY EXTENDED OUTRIGGER CONFIGURATION WHEN LIFTING PERSONNEL.



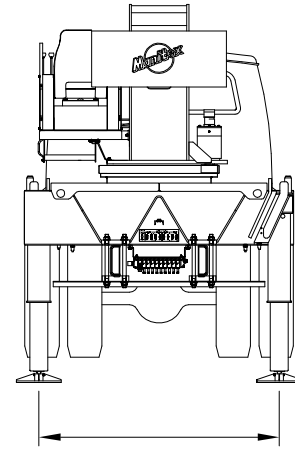



**USE THIS CHART ONLY
WHEN ALL OUTRIGGERS
ARE FULLY RETRACTED**

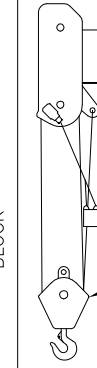
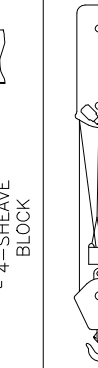

85.75 REF
(7'-1.75 REF)

- FULLY RETRACTED OUTRIGGER CONFIGURATION -

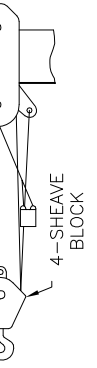
MAIN BOOM LOAD RATINGS IN LBS WITH OUTRIGGERS PLACED AS SHOWN AND THE CRANE LEVEL												
LMI CODE #13												
O P E R A T I N G R A D I U S F T	LOADED BOOM ANGLE		BOOM LENGTH AND MARKER									
					A		B		C		D	
	∠	30.5 FT	∠	40 FT	∠	52 FT	∠	64 FT	∠	76.83 FT		
5	75	80000										
8	69	31050	74	31500	79	31840						
10	65	20180	71	20550	76	20820	80	20990				
12	61	14470	68	14800	74	15030	78	15170	80	15270		
15	54	9640	64	9940	71	10150	75	10270	78	10350		
20	41	5480	55	5770	65	5960	70	6070	74	6140		
25	21	3210	46	3540	58	3730	65	3830	70	3890		
30			34	2130	51	2330	60	2430	66	2490		
35			16	1140	44	1370	55	1470	62	1530		
40					34	670	49	780	58	840		

ALLOWABLE LINE PULL								WARNING
1 PART LINE	2 PART LINE	3 PART LINE	4 PART LINE	5 PART LINE	6 PART LINE	7 PART LINE	8 PART LINE	
								<p>ANTI-TWO-BLOCK SYSTEM MUST BE IN GOOD OPERATING CONDITION BEFORE OPERATING CRANE.</p> <p>REFER TO THE OWNER'S MANUAL.</p> <p>KEEP AT LEAST 3 WRAPS OF LOAD LINE ON THE DRUM AT ALL TIMES.</p>
9500 LBS	19000 LBS	28500 LBS	38000 LBS	47500 LBS	57000 LBS	66500 LBS	76000 LBS	
10000 LBS	20000 LBS	30000 LBS	40000 LBS	50000 LBS	60000 LBS	70000 LBS	80000 LBS	5/8" 6 X 25 IWRC (3.5:1 SF) - 35000 LBS MIN BREAKING STRENGTH

AREA OF OPERATION

WARNING:

THE MACHINE MUST BE LEVEL AND THE FRONT TIRES IN CONTACT WITH THE GROUND OR THE OPTIONAL FRONT BUMPER STABILIZER MUST BE SET WHEN OPERATING IN THIS AREA.

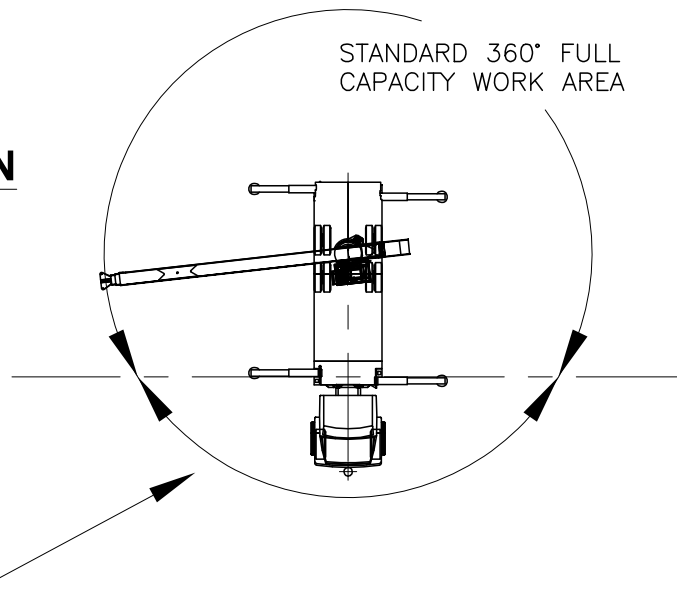

DEDUCTIONS FROM RATED LOADS FOR LOAD HANDLING DEVICES SUPPLIED BY MANITEX

- AUXILIARY BLOCK ----- 50 LBS
- OVERHAUL BALL ----- SEE OVERHAUL BALL MANUFACTURER NAMEPLATE
- LOAD BLOCK ----- SEE BLOCK MANUFACTURER NAMEPLATE
- HOSE REEL ----- 260 LBS
- SWING AROUND JIB (STOWED) ----- SEE LOAD CHART

INFORMATION

1. DEDUCTIONS MUST BE MADE FROM RATED LOADS FOR OPTIONAL ATTACHMENTS, HOOKS, AND LOADBLOCKS (SEE DEDUCTION CHART). WEIGHTS OF SLINGS AND ALL OTHER LOAD HANDLING DEVICES SHALL BE CONSIDERED A PART OF THE LOAD.
2. LOAD RATINGS ABOVE THE HEAVY LINE ARE STRUCTURALLY LIMITED CAPACITIES. LOAD RATINGS BELOW THE HEAVY LINE ARE STABILITY LIMITED CAPACITIES AND DO NOT EXCEED 85% OF TIPPING.

DEFINITIONS

1. OPERATING RADIUS IS THE HORIZONTAL DISTANCE FROM THE AXIS OF ROTATION TO THE CENTER OF THE VERTICAL HOIST LINE OR TACKLE WITH LOAD APPLIED.
2. LOADED BOOM ANGLE AS SHOWN IN THE COLUMN HEADED BY , IS THE INCLUDED ANGLE BETWEEN THE HORIZONTAL AND LONGITUDINAL AXES OF THE BOOM BASE AFTER LIFTING RATED LOAD AT RATED RADIUS.